

# Conference Splitter CS110M

## Description

The CS110M is a high quality microphone distribution amplifier which distributes a controlled microphone signal to ten outputs. Each output can be independently switched to high or low level to interface with a wide variety of recording equipment. The unit is designed to enable any output to be connected to unbalanced equipment without affecting overall gain.

## Features:

**Input** One balanced microphone input via a rear panel mounted XLR connector. Once the coarse level control has been adjusted to suit the microphone and application a slow release level controller maintains the output level. Phantom power (48v), is available for those microphones that require it.

**Output** Ten electronically balanced low impedance outputs on XLR connectors. Each output has an associated front panel switch to insert a 40 dB pad, enabling it to be fed to the microphone input of most audio recorders. The outputs will drive both balanced and unbalanced circuits without affecting the gain of output circuits.

**Options** Transformer balanced input.

## Applications:

The CS110M has been designed to be installed in hotels and conference centres where there is a requirements to distribute one microphone to several users, for instance at press conferences, with the absolute minimum of supervision. The venue needs only to plug in the microphone and make a simple set-up adjustment. The CS110M will then control the output level so that it is consistent from speaker to speaker whether they are softly spoken or more strident. The familiar clutter of microphones in front of the speaker is eliminated.

## Related Products

Audionics manufactures a wide range of high quality audio equipment including distribution amplifiers, audio routing matrices, mixing amplifiers and audio mixers. The WM85 is a small (1U, 19") rackmount mixing unit, ideal for installation alongside the CS110 in conference rooms.

## Key Features

**Electronically balanced input**

**Ten electronically balanced outputs**

**Selectable Mic/Line output level**



**AUDIONICS**  
professional broadcast equipment

**31 JESSOPS RIVERSIDE  
SHEFFIELD**

**S9 2RX**

**ENGLAND**

**TEL +44 (0)114 242 2333**

**FAX +44 (0)114 243 3913**

**email info@audionics.co.uk**

**Web www.audionics.co.uk**



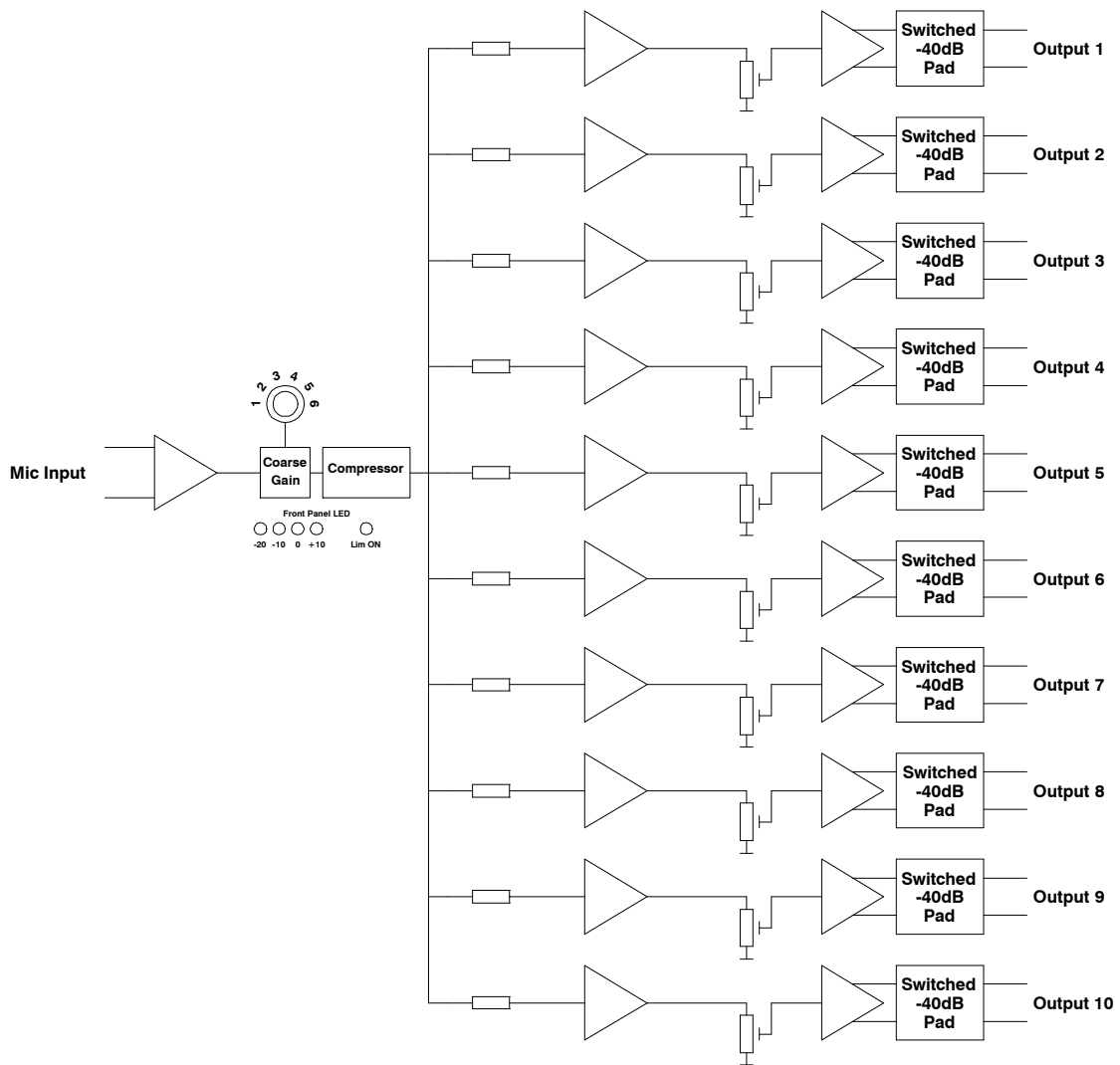

*CS110M* System Diagram

Technical Specifications	CS110
Input Impedance	1k8 ohms
Maximum Input	+22dBu
Output Impedance	50 ohms
Maximum Output	+24 dBu
Line Up Gain Adjust	+6dB, -14dB
Frequency Response	±0.5dB, 100Hz-24kHz
Distortion (THD + Noise)	<0.05%, 100Hz-10kHz @ +20dB
Noise	-120dBu EIN, 20Hz-20kHz
Dimensions	1U (44mm) high, 245mm deep
Power	220-240V, 20W
Weight	5kg

Specification and designs are subject to change without prior notice for the purposes of improvement. E & OE