

# Distribution Amplifiers DA210E DA210T

## Description

The DA210E is a sophisticated, five output, stereo distribution amplifier, housed in a 1U 19" rackmounted case with integral mains power supply. The unit is designed to enable any input or output to be connected to unbalanced equipment without affecting overall gain. The DA210T is a more advanced distribution amplifier with five stereo outputs, which are transformer isolated.

## Features

**Inputs** - Two electronically balanced, (transformer balanced for the DA210T) high impedance inputs, which can be operated in stereo or dual mono mode. As each stereo output has the facility to be monoed, it is possible to configure the unit as dual input mixed to ten mono outputs. Inputs are via XLR connectors and there is the provision for the addition of line termination loads within the unit.

**Outputs** - Ten electronically balanced (transformer balanced for the DA210T) low impedance outputs. Each output has independent gain adjustment of +6dB/-14dB, which enables the amplifier to drive domestic equipment directly. In the stereo mode of operation, each pair of outputs has an on board header to mono the stereo signal. The outputs will drive both balanced and unbalanced circuits without affecting the gain of other outputs.

**Connectors** - All audio inputs and outputs are via 3 pin rear panel XLRs.

**Options** - The DA210E has the option of transformer balanced inputs.

## Applications

The DA210E and DA210T have been designed to provide the user with a versatile method of distributing audio, and transformer balanced audio. The DA210E can provide both balanced and unbalanced machine record feeds in studios. Both amplifiers ability to provide separate mono outputs can be utilised in transmission paths to provide mono transmission, cue and standby feeds.

## Related Products

Audionics manufacture a wide range of audio distribution amplifiers which include the DA216R, a 1U rackmounted, 8 output, resistively split stereo distribution amplifier, and a range of Eurocard amplifiers for standard 3U card frames.

## Key Features

### DA210E

**Electronically balanced inputs and outputs**

**Independent line up of each output**

**Mono header on each output**

**Outputs can drive unbalanced circuits**

### DA210T

**Transformer balanced inputs and outputs**



**AUDIONICS**  
professional broadcast equipment

**31 JESSOPS RIVERSIDE  
SHEFFIELD**

**S9 2RX**

**ENGLAND**

**TEL +44 (0)114 242 2333**

**FAX +44 (0)114 243 3913**

**email [info@audionics.co.uk](mailto:info@audionics.co.uk)**

**Web [www.audionics.co.uk](http://www.audionics.co.uk)**

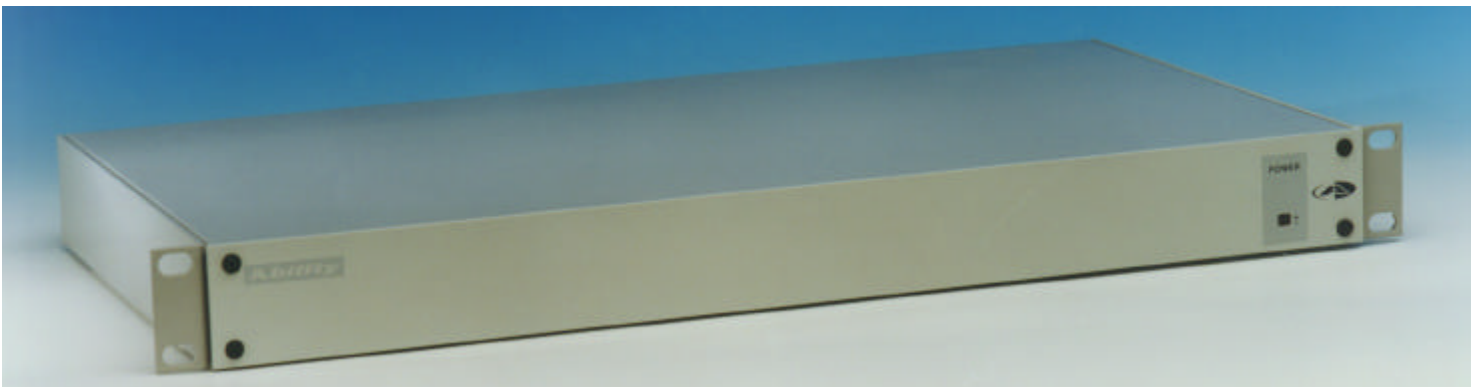

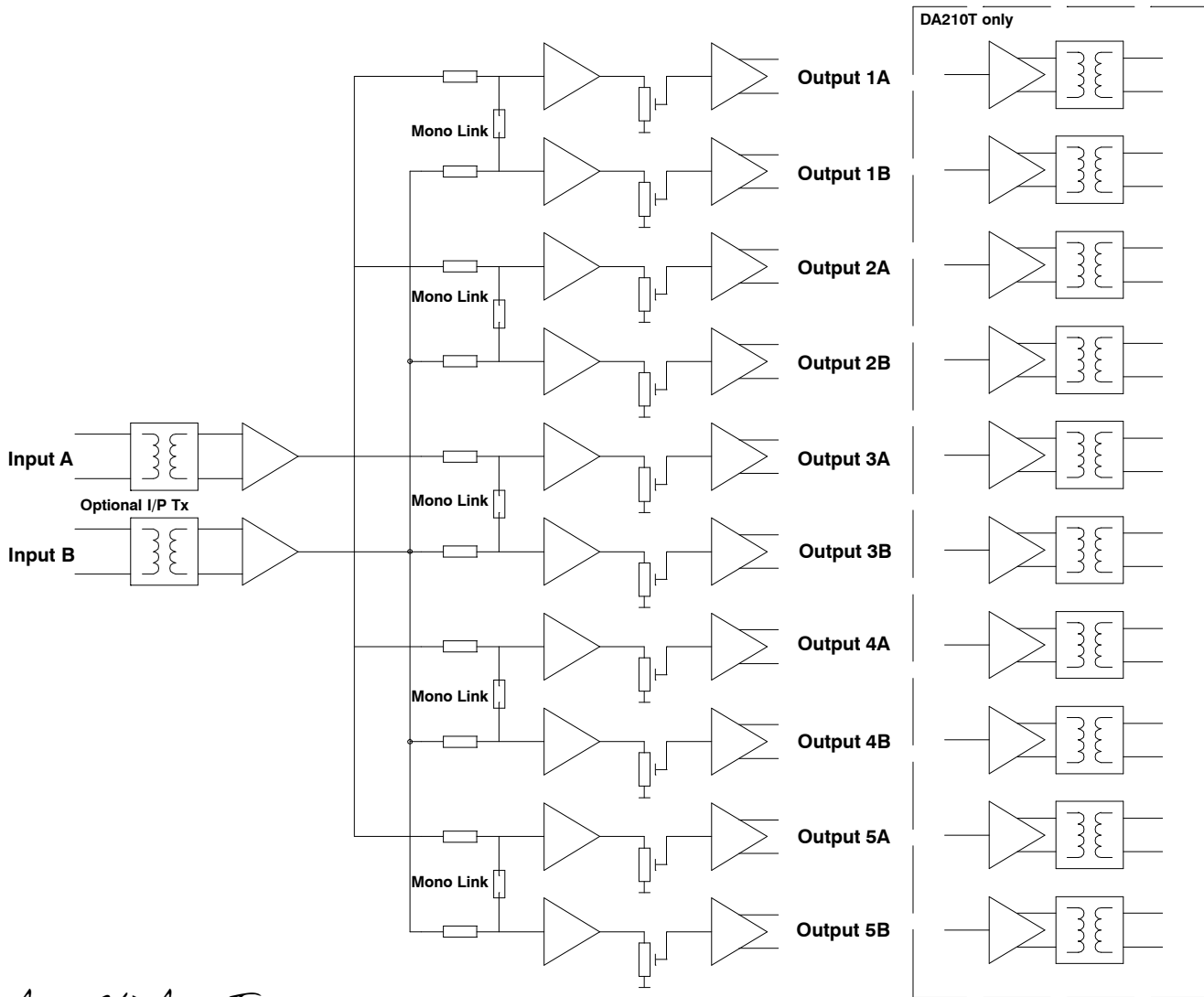

DA210E/DA210T System Diagram

Technical Specifications	DA210E	DA210T
Input Impedance	36k ohms	36k ohms
Maximum Input	+22dBu	+25dBu
Output Impedance	50 ohms	75 ohms
Maximum Output	+24dBu	+25dBu
Output Gain Adjust	+6dB, -14dB	+6dB, -14dB
Crosstalk	<80dB @ 10kHz	<-65dB @ 10kHz
Frequency Response	@0.5dB, 10Hz-24kHz	@0.5dB, 25Hz-24kHz
Distortion (THD + Noise)	<0.01%, 100Hz-10kHz @+20dB	<0.03%, 100Hz-10kHz @+10dBu
Noise	-80dBu peak, 20Hz-20kHz	-70dBu peak, 20Hz-20kHz
Dimensions	1U (44mm) high, 245mm deep	1U (44mm) high, 245mm deep
Power	220-240V, 20W	220-240V, 20W
Weight	5kg	7kg

Specification and designs are subject to change without prior notice for the purposes of improvement. E & OE